

LIQUID CRYSTAL DISPLAY MODULE

G121C00P00C

G121CB1P00C

USER'S MANUAL

Seiko Instruments Inc.

NOTICE

This manual provides technical information covering functions and operational instructions for the G121C liquid crystal display modules with a built-in LCD controller. Please read through this manual before operating the product.

Distribution of this manual to third parties for any purpose other than operation of the product is prohibited. The descriptions herein are subject to change without prior notice. Application information is intended solely for general guidance. Use of the information contained herein for the user's application is done at the user's risk.

Revision Record

<u>Version</u>	<u>Revision</u>	<u>Date</u>
1	Original	September 1994
2		June 1995

Copyright © 1994 by Seiko Instruments Inc.

Printed in Japan

CONTENTS

• G121C00P00C, G121CB1P00C	
1. SPECIFICATIONS	
1.1 General	1
1.2 Features	1
1.3 Absolute Maximum Ratings (excluding LED backlight)	2
1.4 Mechanical Characteristics	2
1.5 Electrical Characteristics (excluding LED backlight)	3
1.6 Optical Characteristics	4
1.7 LCD Panel Lifetime	6
1.8 Dimensions	7
2. CIRCUIT CONFIGURATION	
2.1 Block Diagram	8
2.2 LCD Controller (SEIKO EPSON SED1335F)	9
2.3 Common Driver (HITACHI HD66205TF)	9
2.4 Segment Drivers (HITACHI HD66204TF)	9
2.5 Vopr Control Circuit	10
2.6 Bias Voltage Generator	11
2.7 M' Generator	11
3. OPERATING INSTRUCTIONS	
3.1 Terminal Functions	12
3.2 Timing Characteristics	14
3.3 Reset	16
3.4 Setting the Power Supply and the Signals to On or Off	16
3.5 Commands	17
3.6 Display Data RAM	18
3.7 Example of an Initial Setting	18
3.8 Example of MPU Interface	23
• G121CB1P00C	
4. LED BACKLIGHT	
4.1 Absolute Maximum Ratings	24
4.2 Electro-optical Characteristics	24
4.3 LED Backlight Diagram	24
4.4 Brightness (Top surface of LCD)	24
4.5 Lifetime	25
4.6 Examples of LED Backlight Drivers	25
• G121C00P00C, G121CB1P00C	
5. PRECAUTIONS	
27	
INDEX	

1. SPECIFICATIONS

1.1 General

The G121C is a very thin LCD module which incorporates a full-dot matrix LCD panel and CMOS IC driver. G121C can be used within a wide temperature range. The built-in LCD controller (SED1335F) also interfaces easily with an MPU. This full-dot configuration allows a wide variety of patterns to be displayed depending upon the input data. There is no distortion or displacement in the display because the display position is the point on the matrix where the transparent electrodes intersect.

1.2 Features

G121C00P00C/G121CB1P00C :

- 128 × 128 full dot matrix configuration
- 1/128 duty, 1/10 bias
- Built-in LCD controller SED1335F
- Selectable interface between an 80 series MPU and a 68 series MPU
- 8KB internal display data RAM
- Built-in 160 character (5 × 7 dots) CGROM
- STN LCD with a wide operating temperature range and gray mode
- Positive display
 - Display data “H” : Display ON : blue display color
 - Display data “L” : Display OFF : gray background color

G121C00P00C :

- Dual power supplies : VDD = +5V, VLC = -24V (LCD driving voltage)
- Reflective
- Weight : Approximately 64g

G121CB1P00C :

- Triple power supplies : VDD = +5V, VLC = -24V (LCD driving voltage), LEDA (LED anode)
- Transflective
- Built-in LED backlight (color : yellow-green)
- Weight : Approximately 81g

1.3 Absolute Maximum Ratings (excluding LED backlight)

V_{SS}=0V

Item	Symbol	Conditions	Min.	Max.	Unit
Power supply voltage	V _{DD}		-0.3	7.0	V
	V _{LC}		V _{DD} -30.0	V _{DD}	V
	V _O	V _O ≥ V _{LC}	V _{DD} -30.0	V _{DD}	V
Input voltage	V _{IN}		-0.3	V _{DD} +0.3	V
Operating temperature	T _{opr}	≤ 65%RH	-20	+70	°C
Storage temperature	T _{stg}		-30	+80	°C
Storage humidity		≤ 48 hrs	20	85	%RH
		≤ 1000 hrs	20	65	%RH

1.4 Mechanical Characteristics

Item		Standard
Dot configuration		128×128 dot
Module dimensions (H × V × T)	[mm]	G121C00P00C : 86.0×95.0×8.0 max. G121CB1P00C : 86.0×95.0×10.0 max.
Viewing area (H × V)	[mm]	67.4×67.4
Active display area (H × V)	[mm]	62.69×62.69
Dot dimensions (H × V)	[mm]	0.46×0.46
Dot pitch (H × V)	[mm]	0.49×0.49
Weight	[g]	G121C00P00C : 75 max. G121CB1P00C : 100 max.

H : Horizontal V : Vertical T : Thickness (max.)

1.5 Electrical Characteristics (excluding LED backlight)

$V_{DD}=5V\pm 5\%$, $V_{SS}=0V$, $T_a=-20^{\circ}C$ to $+70^{\circ}C$

Item		Symbol	Conditions	Min	Typ.	Max.	Unit
Power supply voltage		V_{DD}		4.75	5.00	5.25	V
		V_{LC}	$V_{DD}=5V$ $V_O \geq V_{LC}$	-24.5	-24.0	-23.5	V
		V_O		-23.0	—	-5.0	V
Input voltage ¹ (CMOS)	High	V_{IHC}		$0.8V_{DD}$	—	V_{DD}	V
	Low	V_{ILC}		0	—	$0.2V_{DD}$	V
Input voltage ² (TTL)	High	V_{IHT}		$0.5V_{DD}$	—	V_{DD}	V
	Low	V_{ILT}		0	—	$0.2V_{DD}$	V
Input voltage ³ (RES)	High	V_{T+}		$0.5V_{DD}$	$0.7V_{DD}$	$0.8V_{DD}$	V
	Low	V_{T-}		$0.2V_{DD}$	$0.3V_{DD}$	$0.5V_{DD}$	V
Output voltage ⁴	High	V_{OH}	$I_{OH}=-5.0mA$	2.4	—	—	V
	Low	V_{OL}	$I_{OL}=5.0mA$	—	—	0.4	V
Current consumption ⁵		I_{DD}	$V_{DD}=5V$, $T_a=25^{\circ}C$ $V_O=-15.0V$ $f_{FLM}=71.4Hz$	—	10.0	15.0	mA
		I_{LC}		—	4.1	6.2	mA
Frame frequency		f_{FLM}		—	71.4	—	Hz

1 Applied to SEL1 and SEL2.

2 Applied to INH, A0, \overline{CS} , \overline{RD} , \overline{WR} , and D0 to D7.

3 Applied to RES.

4 Applied to D0 to D7.

5 Display patterns : Checkered patterns, Display data shift clock frequency : $f_{CL2} = 6.0MHz$

1.6 Optical Characteristics

1.6.1 G121C00P00C

1/128 duty, 1/10 bias, $f_{FLM}=71.4\text{Hz}$, $V_{opr}=V_{DD}-V_O$

Item	Sym.	Conditions	Temp.	Min.	Typ.	Max.	Unit	Remark
Viewing angle	θ_1	$C \geq 2.0$ $\varnothing=0^\circ$ $V_{opr}=20.0V$	25°C	—	—	-5	Degree	Refer to Notes 1 and 2
	θ_2			50	—	—		
	$\theta_2-\theta_1$			55	—	—		
Contrast	C	$\theta=0^\circ$ $\varnothing=0^\circ$ $V_{opr}=20.0V$	25°C	2.5	3.5	—	—	Note 3
Response time	t_{on}	$\theta=0^\circ$ $\varnothing=0^\circ$ $V_{opr}=20.0V$	25°C	—	150	240	ms	Note 4
	t_{off}			—	110	180		
	t_{on}	$\theta=0^\circ$ $\varnothing=0^\circ$ $V_{opr}=21.5V$	-10°C	—	1060	1700		
	t_{off}			—	500	800		
	t_{on}	$\theta=0^\circ$ $\varnothing=0^\circ$ $V_{opr}=22.0V$	-20°C	—	2860	4600		
	t_{off}			—	780	1300		

Measuring instrument : Canon illuminometer LC-3S

1.6.2 G121CB1P00C

1/128 duty, 1/10 bias, $f_{FLM}=71.4\text{Hz}$, $V_{opr}=V_{DD}-V_O$, backlight : ON

Item	Sym.	Conditions	Temp.	Min.	Typ.	Max.	Unit	Remark
Viewing angle	θ_1	$C \geq 1.4$ $\varnothing=0^\circ$ $V_{opr}=20.0V$	25°C	—	—	-20	Degree	Refer to Notes 1 and 2
	θ_2			30	—	—		
	$\theta_2-\theta_1$			50	—	—		
Contrast	C	$\theta=0^\circ$ $\varnothing=0^\circ$ $V_{opr}=20.0V$	25°C	2.0	2.4	—	—	Note 3
Response time	t_{on}	$\theta=0^\circ$ $\varnothing=0^\circ$ $V_{opr}=20.0V$	25°C	—	150	240	ms	Note 4
	t_{off}			—	110	180		
	t_{on}	$\theta=0^\circ$ $\varnothing=0^\circ$ $V_{opr}=21.5V$	-10°C	—	1060	1700		
	t_{off}			—	500	800		
	t_{on}	$\theta=0^\circ$ $\varnothing=0^\circ$ $V_{opr}=22.0V$	-20°C	—	2860	4600		
	t_{off}			—	780	1300		

Measuring instrument : Canon illuminometer LC-3S

Note 1 : Definition of angle θ and ϕ

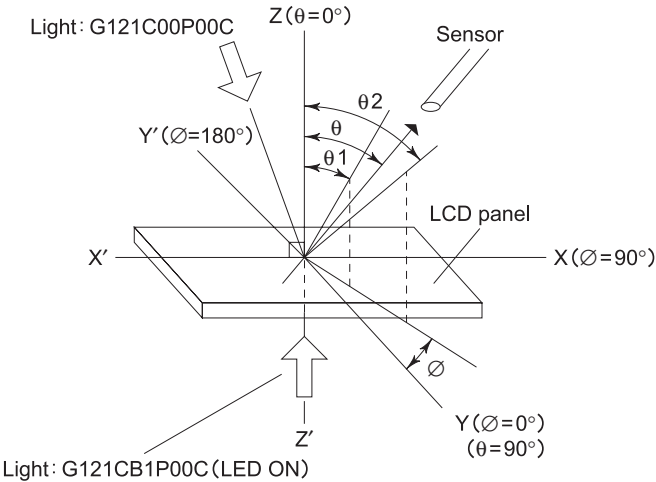

Note 2 : Definition of viewing angles θ_1 and θ_2

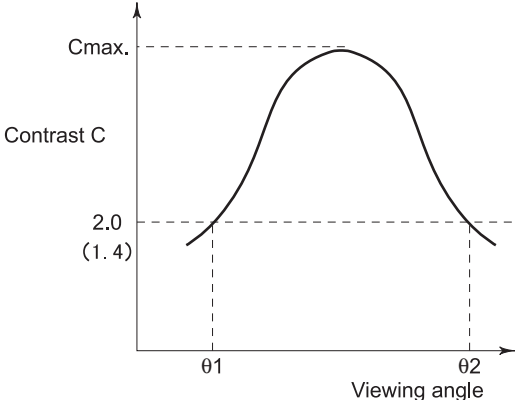

Remark : The optimum viewing angle by visual inspection and angle θ at C_{max} do not always match.

Note 3 : Definition of contrast (C)

$$C = \frac{\text{Brightness of non-selected dot } B_2}{\text{Brightness of selected dot } B_1}$$

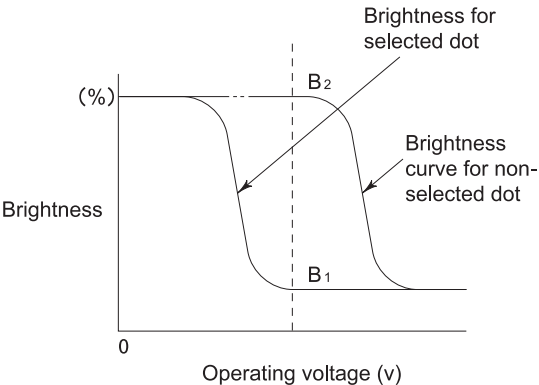

Note 4 : Definition of response time

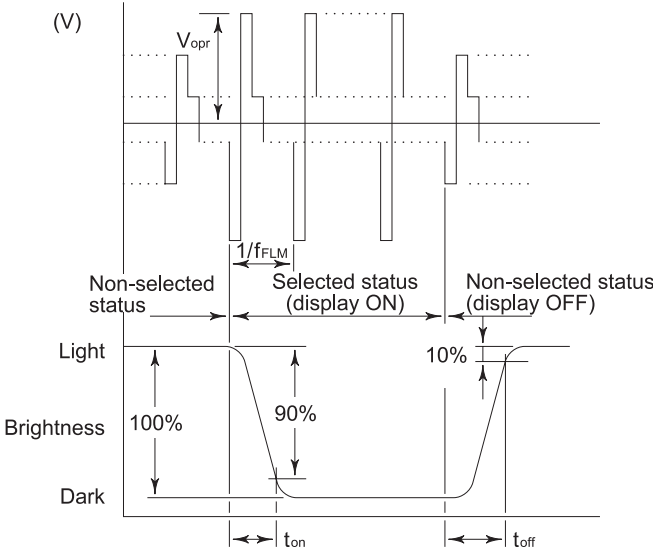

V_{opr} : Operating voltage t_{on} : Response time (rise)
 f_{FLM} : Frame frequency t_{off} : Response time (fall)

Note : The measurements must be made using a G121C transmissive LCD panel.

Figure 1 Definition

1.7 LCD Panel Lifetime

Item	Conditions	Standard	Unit
Lifetime*	25°C±10°C <65%RH	100,000 or more	hrs

* Definition of lifetime : the time up to occurrence of any of the following :

- Contrast reduces to 30% of the initial value.
- Current consumption becomes three times the initial value.
- Orientation deteriorates significantly.
- The display malfunctions.

1.8 Dimensions

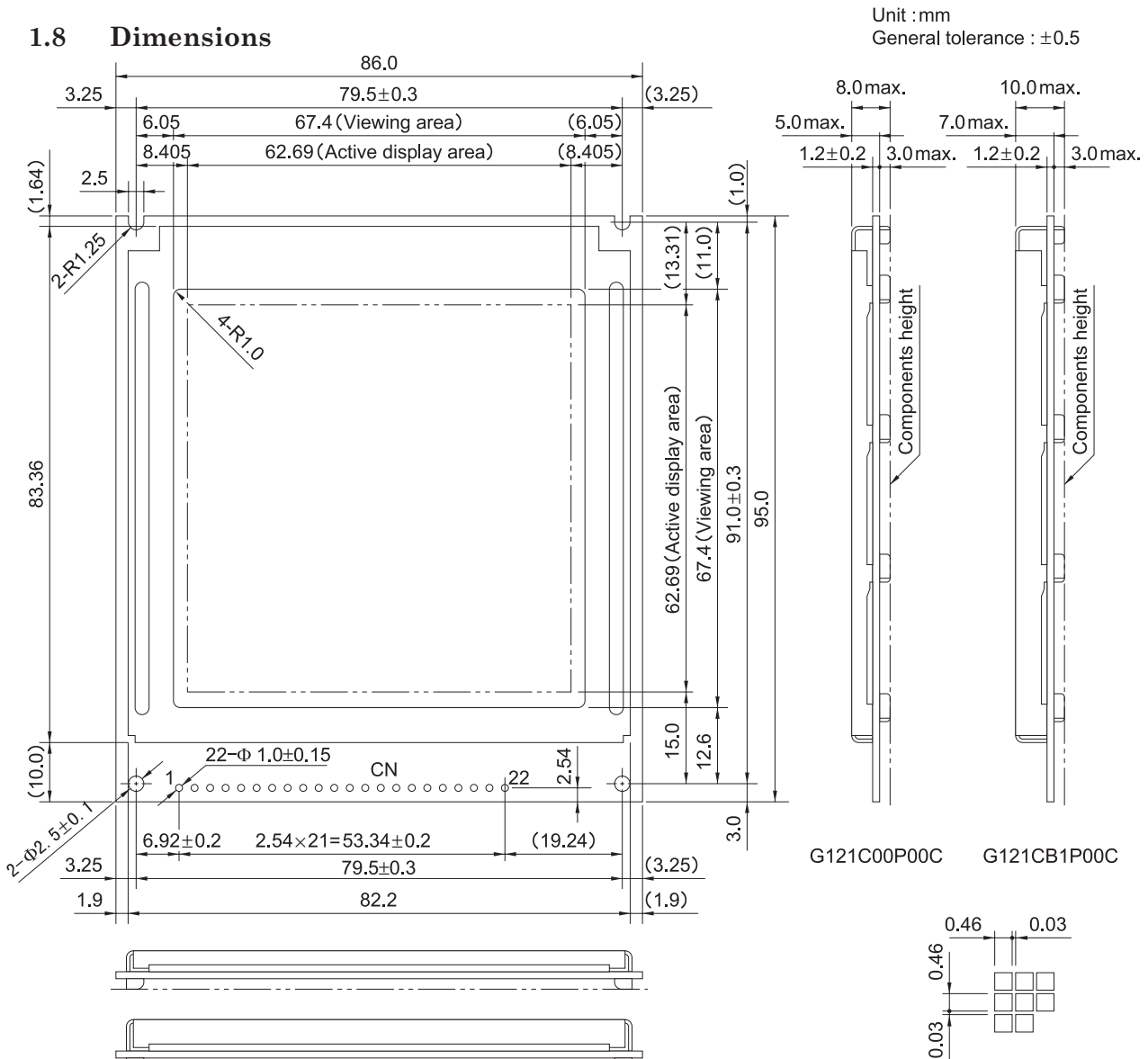

Figure 2 Dimensions

I/O terminal functions

No.	Sym.	Functions
1	RES	Reset signal input
2	RD	80 series MPU ... Read signal 68 series MPU ... "E" clock
3	WR	80 series MP ... Write signal 68 series MP ... R/W signal
4	SEL2	80/68series MPU bus switching terminal
5	SEL1	80/68series MPU bus switching terminal
6	CS	Chip select input
7	A0	Identifying signal for data bus signal
8	D ₀	Data bus line
9	D ₁	Data bus line
10	D ₂	Data bus line

No.	Sym.	Functions
11	D ₃	Data bus line
12	D ₄	Data bus line
13	D ₅	Data bus line
14	D ₆	Data bus line
15	D ₇	Data bus line
16	V _{DD}	Power supply for logic circuit (+5V)
17	V _{SS}	GND (0V)
18	V _O	Adjustment terminal for liquid crystal driving voltage
19	V _{LC}	Power supply terminal for driving liquid crystal display (-24V)
20	INH ¹	Display on/off control terminal
21	NC/LEDA	— ²
22	NC/LEDC	— ²

1 After powering on, DC voltage is not applied to LCD by setting INH "L" until the initialization of LCD controller is completed. After DISP ON command is executed, the display is set to on by setting INH "H" and set to off by setting INH "L".

2 G121C00P00C : NC

G121CB1P00C : Power supply for LED backlight (No.21 : LEDA, No.22 : LEDC)

2. CIRCUIT CONFIGURATION

2.1 Block Diagram

G121C**P**C consists of an LCD controller, display data RAM, common drivers, segment drivers, a V_{opr} control circuit, a bias voltage generator, M' generator and so forth. Figure 3 shows the block diagram.

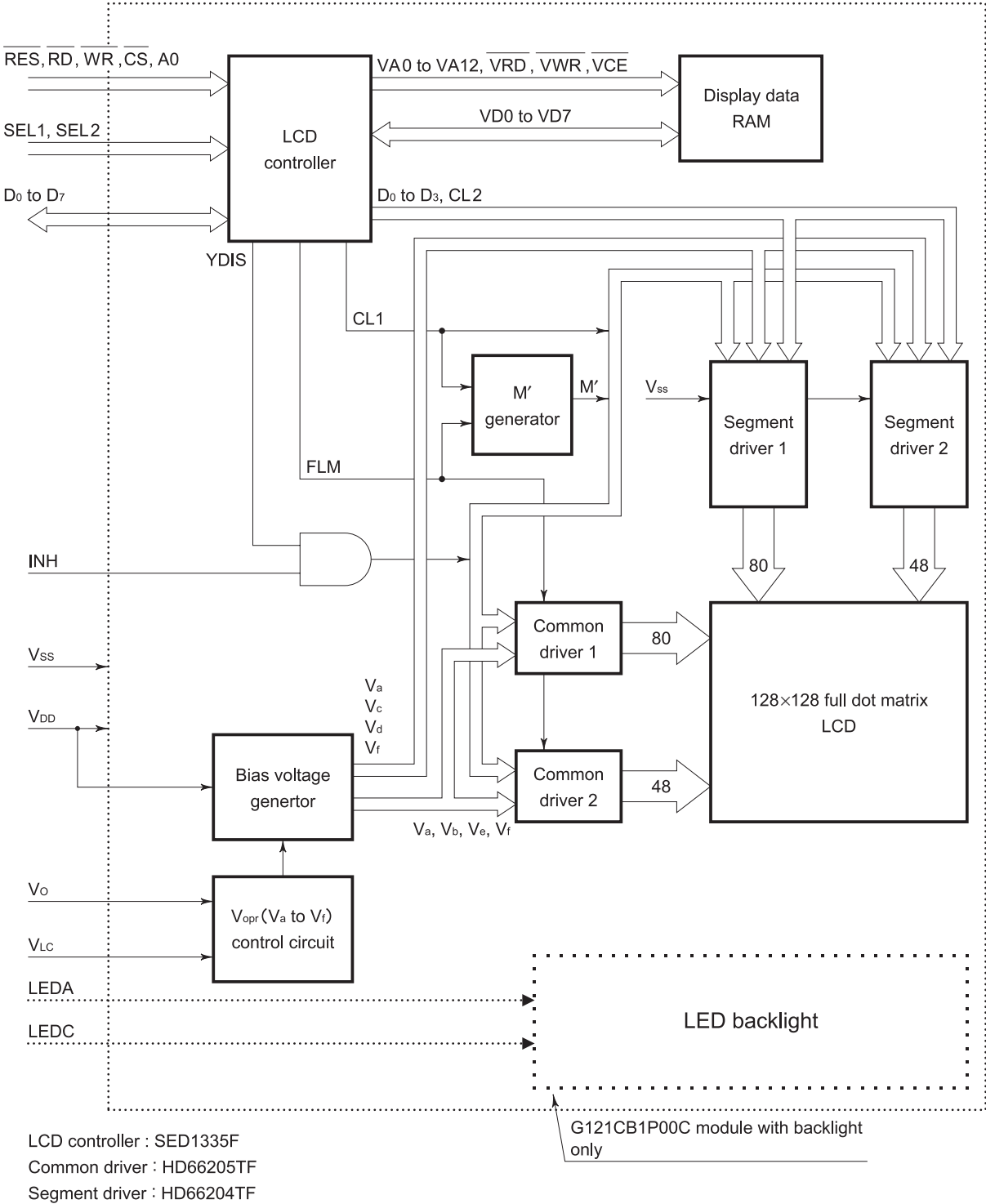

Figure 3 Block Diagram

2.2 LCD Controller (SEIKO EPSON SED1335F)

The LCD controller (SED1335F) is located between the MPU and the LCD panel. The LCD controller stores the character codes and the bit-mapped graphics data from the MPU in the display data RAM (8KB), and then periodically reads out the stored data, converts it, and sends the converted signal to the LCD module. Also, through many command functions, it is possible to overlap the character screen with the graphics screen and scroll the screen in all directions.

2.3 Common Driver (HITACHI HD66205TF)

The common driver (CD) is an 80 drive output CMOS IC. Two CDs are used in conjunction with each other in the G121C and operate as follows :

The CDs read the input one-frame timing signal (FLM) into the internal register at the one-common line timing signal (CL1) fall edge trigger and shift it sequentially. The common drive waveform is formed by the contents of this shift register and the signal to make the liquid crystal drive waveform AC (M'). There are six voltage levels (Va to Vf) in the waveform. Table 1 shows the description of each level. Note that FLM signal and CL1 signal are input from LCD controller. After CL1 is input 128 times, the next FLM is input and the same operation is repeated.

Table 1 Description of each voltage level

V _a	Common, segment selection level
V _b	Common non-selection level
V _c	Segment non-selection level
V _d	Segment non-selection level
V _e	Common non-selection level
V _f	Common, segment selection level

INH signal and YDIS signal from the LCD controller control COM output. When INH signal or YDIS signal is set to "L", V_a is output to COM output regardless of the contents of the shift register and M' signal.

2.4 Segment Driver (HITACHI HD66204TF)

The segment driver is an 80 drive output CMOS IC. Two segment drivers are used in the G121C and operate as follows :

4 bit input display data is read sequentially into the internal register at the display data shift clock (CL2) fall edge trigger. This display data and CL2 signal are input from the LCD controller. Because a chip enable function is built into the segment driver, when the 80 bit

display data is input to SD1, the next data is automatically sent to segment driver 2. The two segment drivers read 128 bit display data. Thus the input display data in the internal register is latched at the one-common line timing signal (CL1) fall edge trigger. The segment drive waveform is formed by the display data and the signal to make the liquid crystal drive waveform AC (M').

The INH signal and the YDIS signal from the LCD controller control SEG output. When the INH signal or the YDIS signal is set to "L", V_a is output to SEG output regardless of the contents of the shift register and M' signal. Consequently, when the INH at the input terminal or the YDIS signal from the LCD controller is set to "L", V_a is applied to COM output and SEG output, 0V is applied to the liquid crystal and the display is set to off.

2.5 V_{opr} control circuit

The viewing angle of the LCD panel and the shade of the screen depends on the liquid crystal operating voltage (V_{opr}). With the G121C, VLC is applied from outside. This VLC, as shown in Figure 4, is supplied with an operational amplifier and the voltage V_{opr} (V_a to V_f) applied to the LCD panel is generated.

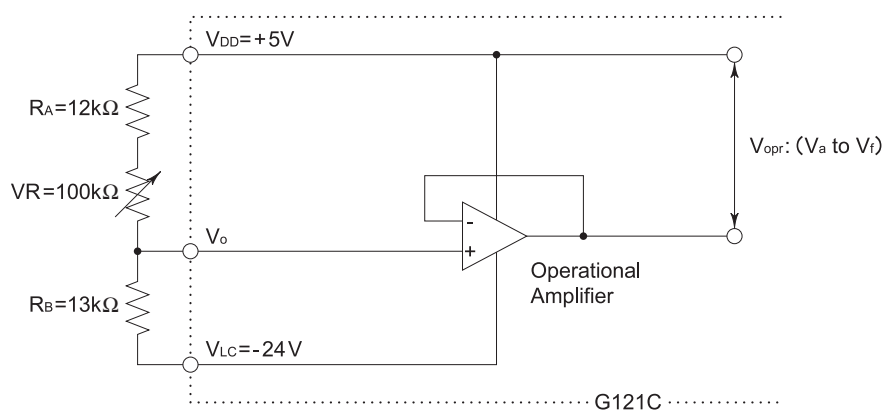

Figure 4 V_{opr} Control Circuit

Also, the viewing angle of the LCD panel and shade of the screen depend on the ambient temperature. The recommended values of the V_{opr} for the ambient temperature are as follows :

Table 2 LC operating voltage

Temperature (°C)	-20	0	25	50	70
Voltage(V_{opr})* (V)	22.0	21.5	20.0	19.0	18.0

* $V_{opr} \approx V_{DD} - V_O$

2.6 Bias Voltage Generator

Six levels of voltage V_a to V_f are applied to the drivers as a bias voltage. This voltage is generated from V_{opr} by dividing the resistance and driven by a voltage follower through an operational amplifier.

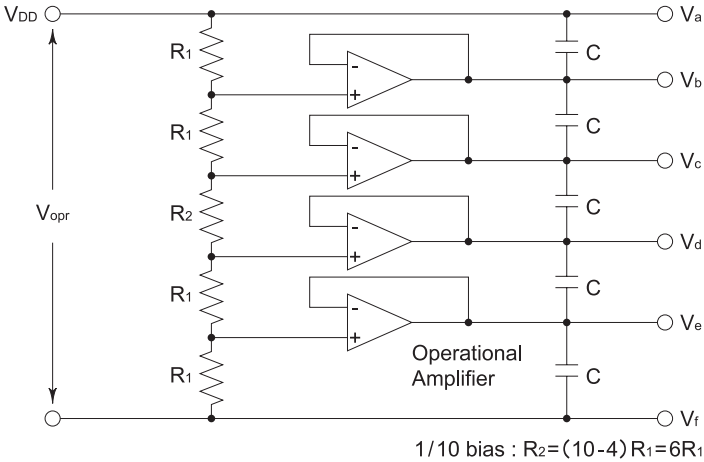

Figure 5 Bias Voltage Generator

2.7 M' Generator

M' generator outputs the Ex-ORed signal between the divided signal of the one-common line timing signal (CL1) to A and the divided signal of the one-frame timing signal (FLM) to B as M' , which makes up the LC drive waveform AC. The values of A and B are set according to the LC panel to allow for the best quality display and to allow the drive voltage to be converted to AC.

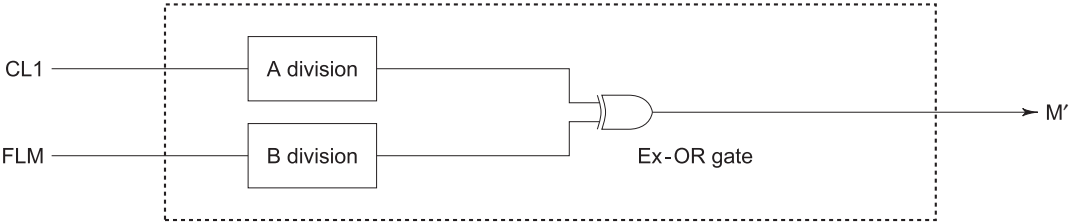

Figure 6 M' generator

3. OPERATING INSTRUCTIONS

3.1 Terminal Functions

Table 3 Terminal Functions 1

Signal	Q'ty	I/O	Functions																																			
$\overline{\text{RES}}$	1	Input	Active "L" Executes initial reset to the LCD controller by hardware.																																			
$\overline{\text{RD}}$	1	Input	<ul style="list-style-type: none"> 80 series MPU Active "L" Strobe signal when MPU reads out the data or the status flag from the LCD controller. The data bus of LCD controller is set to the output status during "L" 68 series MPU Active "H" Enable clock input terminal of 68 series MPU 																																			
$\overline{\text{WR}}$	1	Input	<ul style="list-style-type: none"> 80 series MPU Active "L" Strobe signal when 80 series MPU writes the data or the parameters into LCD controller. LCD controller fetches the data bus signal at the $\overline{\text{WR}}$ rise edge. 68 series MPU R/$\overline{\text{W}}$ control signal input terminal of 68 series MPU. R/$\overline{\text{W}}$= "H" : READ R/$\overline{\text{W}}$= "L" : WRITE 																																			
SEL1 SEL2	1 1	Input Input	<p>MPU interface can be switched by the combination of SEL1 and SEL2, and can be connected directly to both 80 series MPU (Z80, 8085, etc.) data bus and 68 series MPU (6809, 6802) data bus.</p> <table border="1"> <thead> <tr> <th>SEL1</th> <th>SEL2</th> <th>Interface</th> <th>A0</th> <th>$\overline{\text{RD}}$</th> <th>$\overline{\text{WR}}$</th> <th>$\overline{\text{CS}}$</th> </tr> </thead> <tbody> <tr> <td>0</td> <td>0</td> <td>80 series</td> <td>A0</td> <td>$\overline{\text{RD}}$</td> <td>$\overline{\text{WR}}$</td> <td>$\overline{\text{CS}}$</td> </tr> <tr> <td>1</td> <td>0</td> <td>68 series</td> <td>A0</td> <td>E</td> <td>R/$\overline{\text{W}}$</td> <td>$\overline{\text{CS}}$</td> </tr> <tr> <td>0</td> <td>1</td> <td>*</td> <td>*</td> <td>*</td> <td>*</td> <td>*</td> </tr> <tr> <td>1</td> <td>1</td> <td>*</td> <td>*</td> <td>*</td> <td>*</td> <td>*</td> </tr> </tbody> </table> <p>* : Prohibited</p> <p>Normally SEL1 and SEL2 are directly connected to either power supply VDD or VSS to prevent noise.</p>	SEL1	SEL2	Interface	A0	$\overline{\text{RD}}$	$\overline{\text{WR}}$	$\overline{\text{CS}}$	0	0	80 series	A0	$\overline{\text{RD}}$	$\overline{\text{WR}}$	$\overline{\text{CS}}$	1	0	68 series	A0	E	R/ $\overline{\text{W}}$	$\overline{\text{CS}}$	0	1	*	*	*	*	*	1	1	*	*	*	*	*
SEL1	SEL2	Interface	A0	$\overline{\text{RD}}$	$\overline{\text{WR}}$	$\overline{\text{CS}}$																																
0	0	80 series	A0	$\overline{\text{RD}}$	$\overline{\text{WR}}$	$\overline{\text{CS}}$																																
1	0	68 series	A0	E	R/ $\overline{\text{W}}$	$\overline{\text{CS}}$																																
0	1	*	*	*	*	*																																
1	1	*	*	*	*	*																																
$\overline{\text{CS}}$	1	Input	Active "L" Inputs the chip select signal normally acquired by decoding the address bus signal when the MPU accesses the LCD controller.																																			

Table 4 Terminal Functions 2

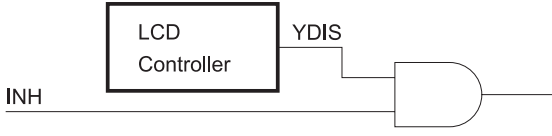
Signal	Q'ty	I/O	Functions																																								
A0	1	Input	<p>Normally connected to the least significant bit of MPU address. The data bus signal is identified by the combination of RD and WR or R/W and E as shown in the following tables:</p> <p><80 series interface></p> <table border="1"> <thead> <tr> <th>A0</th> <th>\overline{RD}</th> <th>\overline{WR}</th> <th>functions</th> </tr> </thead> <tbody> <tr> <td>0</td> <td>0</td> <td>1</td> <td>Reads out the status flag</td> </tr> <tr> <td>1</td> <td>0</td> <td>1</td> <td>Reads out the data (display data, cursor address)</td> </tr> <tr> <td>0</td> <td>1</td> <td>0</td> <td>Writes the data (display data, parameters)</td> </tr> <tr> <td>1</td> <td>1</td> <td>0</td> <td>Writes commands (only codes)</td> </tr> </tbody> </table> <p><68 series interface></p> <table border="1"> <thead> <tr> <th>A0</th> <th>\overline{RD} (E)</th> <th>\overline{WR} (R/W)</th> <th>functions</th> </tr> </thead> <tbody> <tr> <td>0</td> <td>1</td> <td>1</td> <td>Reads out the status flag</td> </tr> <tr> <td>1</td> <td>1</td> <td>1</td> <td>Reads out the data (display data, cursor address)</td> </tr> <tr> <td>0</td> <td>1</td> <td>0</td> <td>Writes the data (display data, parameters)</td> </tr> <tr> <td>1</td> <td>1</td> <td>0</td> <td>Writes commands (only codes)</td> </tr> </tbody> </table>	A0	\overline{RD}	\overline{WR}	functions	0	0	1	Reads out the status flag	1	0	1	Reads out the data (display data, cursor address)	0	1	0	Writes the data (display data, parameters)	1	1	0	Writes commands (only codes)	A0	\overline{RD} (E)	\overline{WR} (R/W)	functions	0	1	1	Reads out the status flag	1	1	1	Reads out the data (display data, cursor address)	0	1	0	Writes the data (display data, parameters)	1	1	0	Writes commands (only codes)
A0	\overline{RD}	\overline{WR}	functions																																								
0	0	1	Reads out the status flag																																								
1	0	1	Reads out the data (display data, cursor address)																																								
0	1	0	Writes the data (display data, parameters)																																								
1	1	0	Writes commands (only codes)																																								
A0	\overline{RD} (E)	\overline{WR} (R/W)	functions																																								
0	1	1	Reads out the status flag																																								
1	1	1	Reads out the data (display data, cursor address)																																								
0	1	0	Writes the data (display data, parameters)																																								
1	1	0	Writes commands (only codes)																																								
D0 to D7	8	I/O	Active "H" Tristate input/output terminal 8 bit bidirectional data bus. Connected to 8 bit or 16 bit MPU data bus.																																								
VDD	1	—	Power supply for logic circuit (+5V)																																								
VSS	1	—	GND (0V)																																								
V ₀	1	—	Adjustment terminal for liquid crystal driving voltage																																								
VLC	1	—	Power supply terminal for driving liquid crystal display (-24V)																																								
INH	1	Input	<p>When INH= "H", the display is ON and when INH= "L", the display is OFF.</p> 																																								
LEDA	1	—	G121C00P00C : NC G121CB1P00C : LED backlight anode terminal																																								
LEDC	1	—	-G121C00P00C : NC G121CB1P00C : LED backlight cathode terminal																																								

3.2 Timing Characteristics

3.2.1 Read/Write Characteristics (80 series MPU)

$T_a = -20^{\circ}\text{C} \sim +70^{\circ}\text{C}$, $V_{DD} = 5.0\text{V} \pm 5\%$, $V_{SS} = 0\text{V}$

Signal	Item	Symbol	Min.	Typ.	Max.	Unit
A0, $\overline{\text{CS}}$	Address hold time	t_{AH8}	10	—	—	ns
	Address setup time	t_{AW8}	0	—	—	ns
$\overline{\text{WR}}$, $\overline{\text{RD}}$	System cycle time	t_{CYC8}	*	—	—	ns
	Control pulse width	t_{CC}	120	—	—	ns
D0 to D7	Data hold time	t_{DH8}	5	—	—	ns
	Data setup time	t_{DS8}	120	—	—	ns
	$\overline{\text{RD}}$ access time	t_{ACC8}	—	—	50	ns
	Output disable time	t_{OH8}	10	—	50	ns

* $t_{CYC8} = 785$: Applies to "Memory control command" and "System control command."

($t_{CYC8} = 2t_c + t_{CC} + t_{CEA} + 75 > t_{ACT} + 245$)

$t_{CYC8} = 820$: Applies to all the commands except the commands above.

($t_{CYC8} = 4t_c + t_{CC} + 30$)

Timing Chart

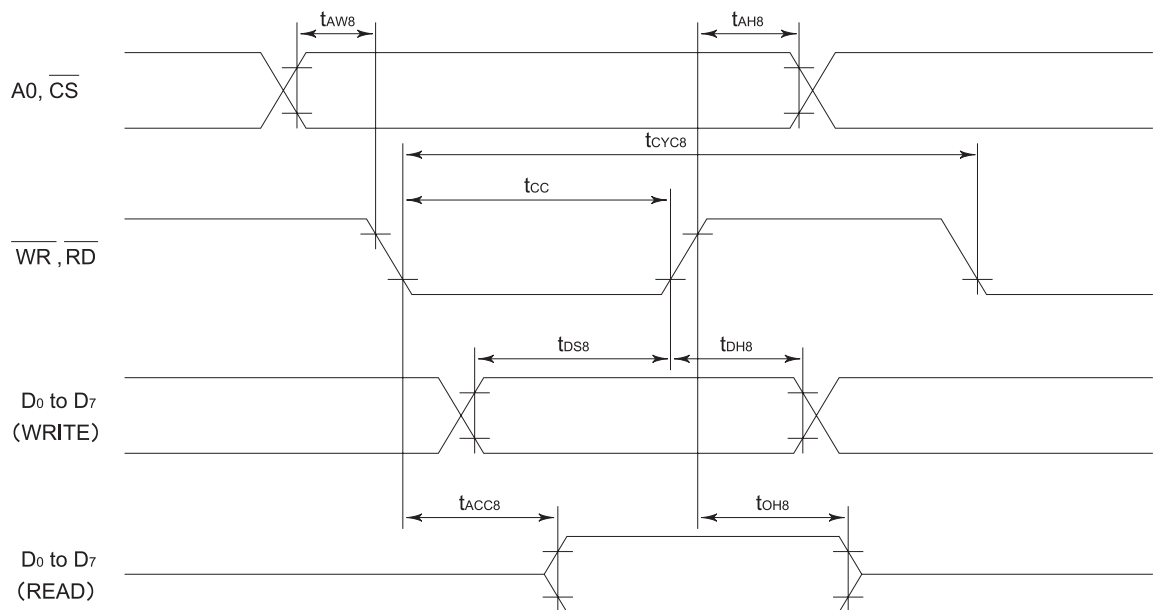

3.2.2 Read/Write Characteristics (68 series MPU)

Ta = -20°C ~ +70°C, V_{DD} = 5.0V ± 5%, V_{SS} = 0V

Signal	Item	Symbol	Min.	Typ.	Max.	Unit
A0, $\overline{\text{CS}}$, $\overline{\text{WR}}$	Address hold time	t _{AH6}	0	—	—	ns
	Address setup time	t _{AW6}	0	—	—	ns
	System cycle time	t _{CYC6}	*	—	—	ns
D ₀ to D ₇	Data hold time	t _{DH6}	0	—	—	ns
	Data setup time	t _{DS6}	100	—	—	ns
	Access time	t _{ACC6}	—	—	85	ns
	Output disable time	t _{OH6}	10	—	50	ns
$\overline{\text{RD}}$	Enable pulse width	t _{RDW}	120	—	—	ns

*t_{CYC6} = 785 : Applies to "Memory control command" and "System control command."

(t_{CYC6} = 2t_C + t_{RDW} + t_{CEA} + 75 > t_{ACV} + 245)

t_{CYC6} = 820 : Applies to all the commands except the commands above.

(t_{CYC6} = 4t_C + t_{CC} + 30)

Note : t_{CYC6} indicates the cycle of $\overline{\text{RD}}$ (E) signal while $\overline{\text{CS}} \cdot \overline{\text{RD}}$ (E) = "H." It doesn't unconditionally indicate the cycle of $\overline{\text{RD}}$ (E) signal.

Timing Chart

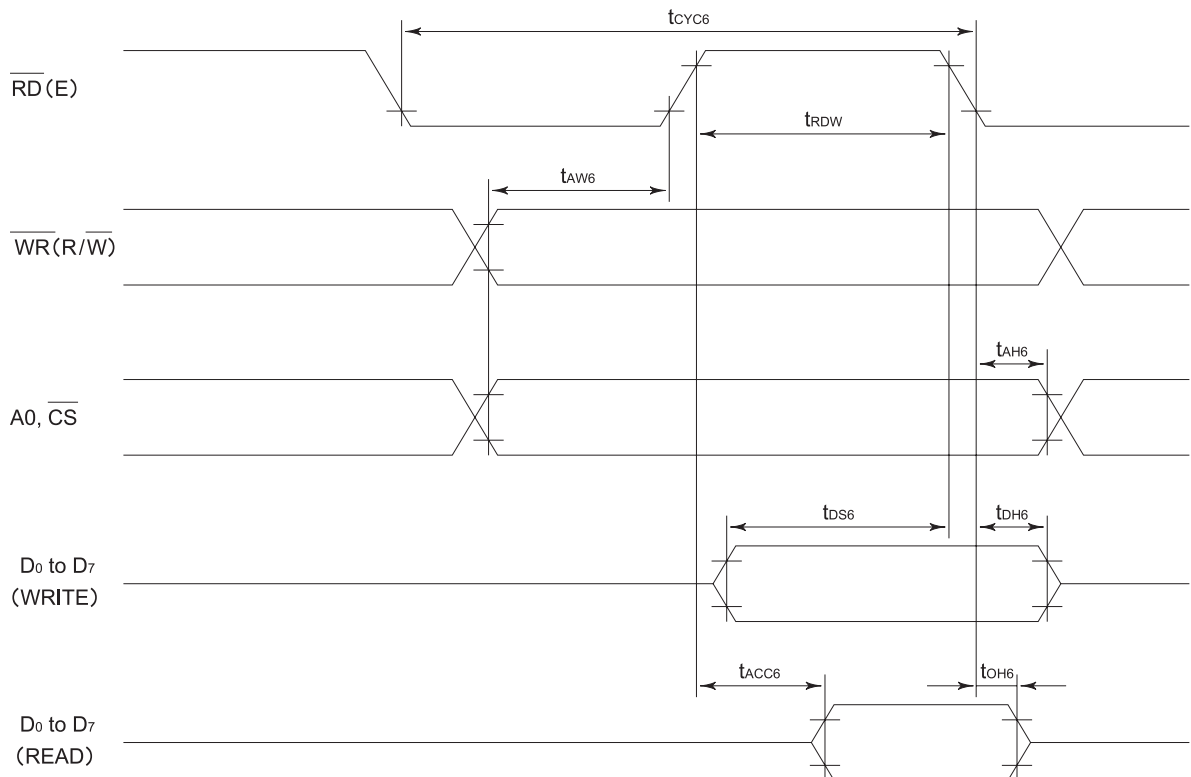

3.3 Reset

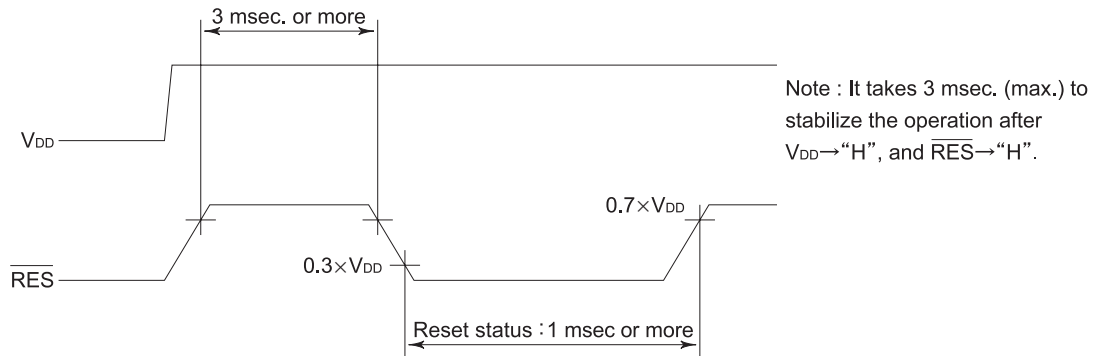

Figure 7 Reset

Inputting reset pulse resets the internal status of the LCD controller after powering on. The width of the pulse input must be 1 msec or more.

The control signal for the LCD is cut off when in the reset status. Consequently, the LCD is driven by DC and the display quality deteriorates. Therefore, set \overline{INH} to L to reset in the status in which DC is not applied to LCD. The instructions from the CPU cannot be accepted during this period. After resetting, set the default values immediately in order to set the internal registers after resetting.

3.4 Setting the Power Supply and the Signals to On or OFF

Set the power supply and the signals to on or off according to the following timing chart list to avoid malfunctions of the drive circuit and the LC panel.

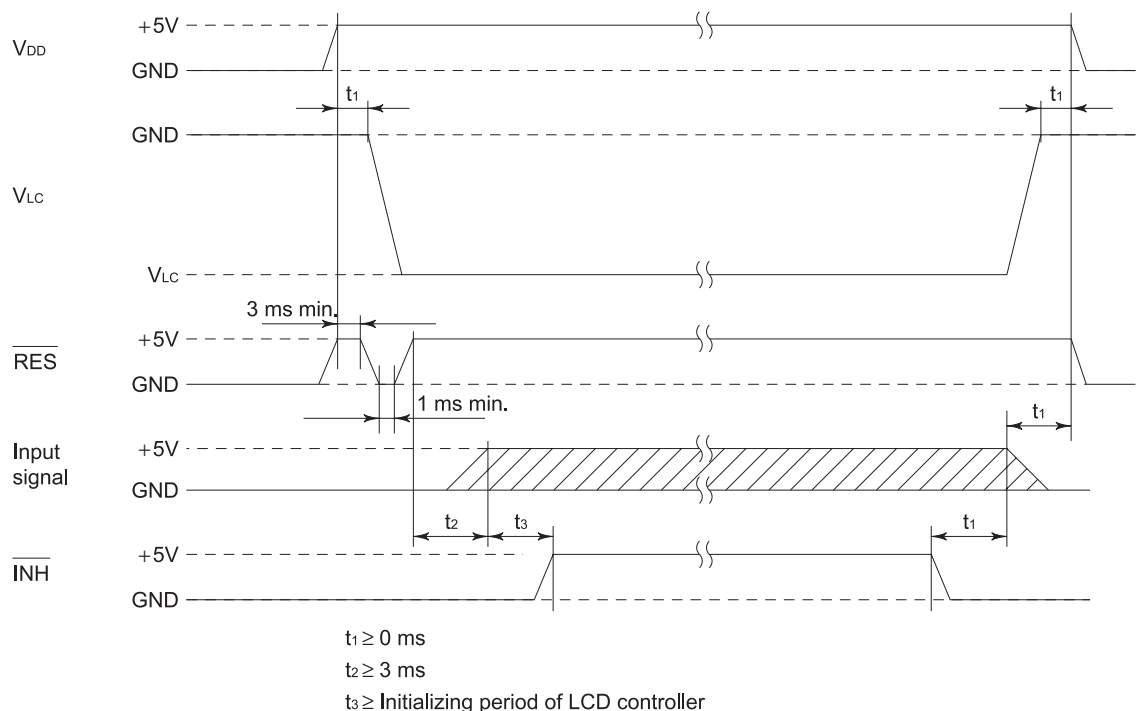

Figure 8 Timing of setting the power supply and the signals to on and off

3.5 Commands

Table 5 Commands

Purpose	Command	Code		HEX	Description	Parameters	Remarks
		$\overline{\text{RD}}$ $\overline{\text{WR}}$ A0	D7 D6 D5 D4 D3 D2 D1 D0				
System Control	SYSTEM SET	1 0 1	0 1 0 0 0 0 0 0	40	Setting the initial operation and the window	P1 to P8	Note 1
	SLEEP IN	1 0 1	0 1 0 1 0 0 1 1	53	Sleep Operation	0	
Display Control	DISP ON/OFF	1 0 1	0 1 0 1 1 0 0 D	58 59	Display on/off, flashing screen	P1	
	SCROLL	1 0 1	0 1 0 0 0 1 0 0	44	Setting display start address and the display area	P1 to P10	Note 1
	CSRFORM	1 0 1	0 1 0 1 1 1 0 1	5D	Setting the shape of the cursor, etc.	P1, P2	
	CGRAM ADR	1 0 1	0 1 0 1 1 1 0 0	5C	Setting CG RAM start address	P1, P2	Note 1
	CSDIR	1 0 1	0 1 0 0 1 1 1 0 ^{CD CD}	4C to 4F	Setting the cursor movement direction	0	
	HDOT SCR	1 0 1	0 1 0 1 1 0 1 0	5A	Setting the scrolling position per dot in the horizontal direction	P1	
	OVLAY	1 0 1	0 1 0 1 1 0 1 1	5B	Display overlaying mode	P1	
Drawing Control	CSRW	1 0 1	0 1 0 0 0 1 1 0	46	Setting cursor address	P1, P2	Note 1
	CSRR	1 0 1	0 1 0 0 0 1 1 1	47	Reading cursor address	P1, P2	Note 1
Memory Control	MWRITE	1 0 1	0 1 0 0 0 0 1 0	42	Writing into display memory	—	
	MREAD	1 0 1	0 1 0 0 0 0 1 1	43	Reading display memory data	—	

Note 1) A command is executed every time each parameter is input to the LCD controller and completed when the following parameters (P) or command (C) is entered. Consequently, the MPU can abort sending the parameters and send the following command. In this case the parameters which have been sent are effective and the values of the remaining parameters which have not been sent remain unchanged. Note that 2 byte parameters are handled as follows :

- 1) CSRW and CSRR commands : Parameters are executed per byte. Consequently only the lower bytes can be changed or checked.
- 2) All the commands but CSRW and CSRR commands : Executed after the second byte of the parameter is entered.

(SYSTEM SET, SCROLL, CGRAM ADR)

* 2 byte parameter indicates 1 data with 2 bytes such as APL and APH.

For a description of commands and their parameters, refer to "SED1335F/1336F LCD Controller IC Application Manual" (Seiko Epson Corporation).

3.6 Display Data RAM

The built-in LCD controller can control 512 Kbit (0000H to FFFFH) of the VRAM area. However, because the G121C has only 64 Kbit of built-in VRAM, the upper 3 bits are not effective. Consequently, when you define the addresses over 2000H, the display data is destroyed because the data is mapped to the VRAM area defined by the lower 13 bits. Do not map the data onto addresses over 2000H.

When you define 65 or more customized character fonts (max. 256 characters) on CGRAM and display them simultaneously, you must map them onto VRAM addresses F000H through FFFFH. Note that this corresponds to 1000H through 1FFFH in VRAM of the G121C.

Because all the character codes are assigned to CGRAM, the built-in CGROM cannot be used together with CGRAM.

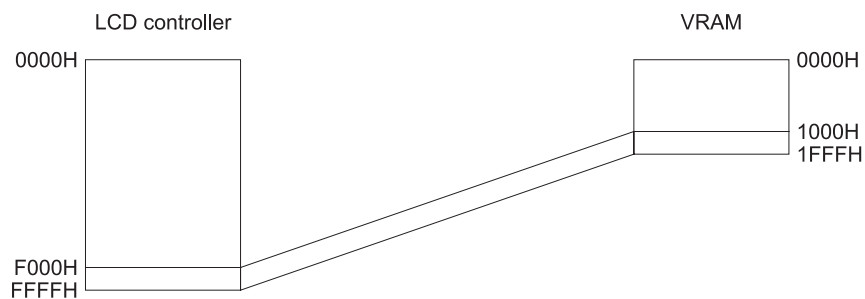
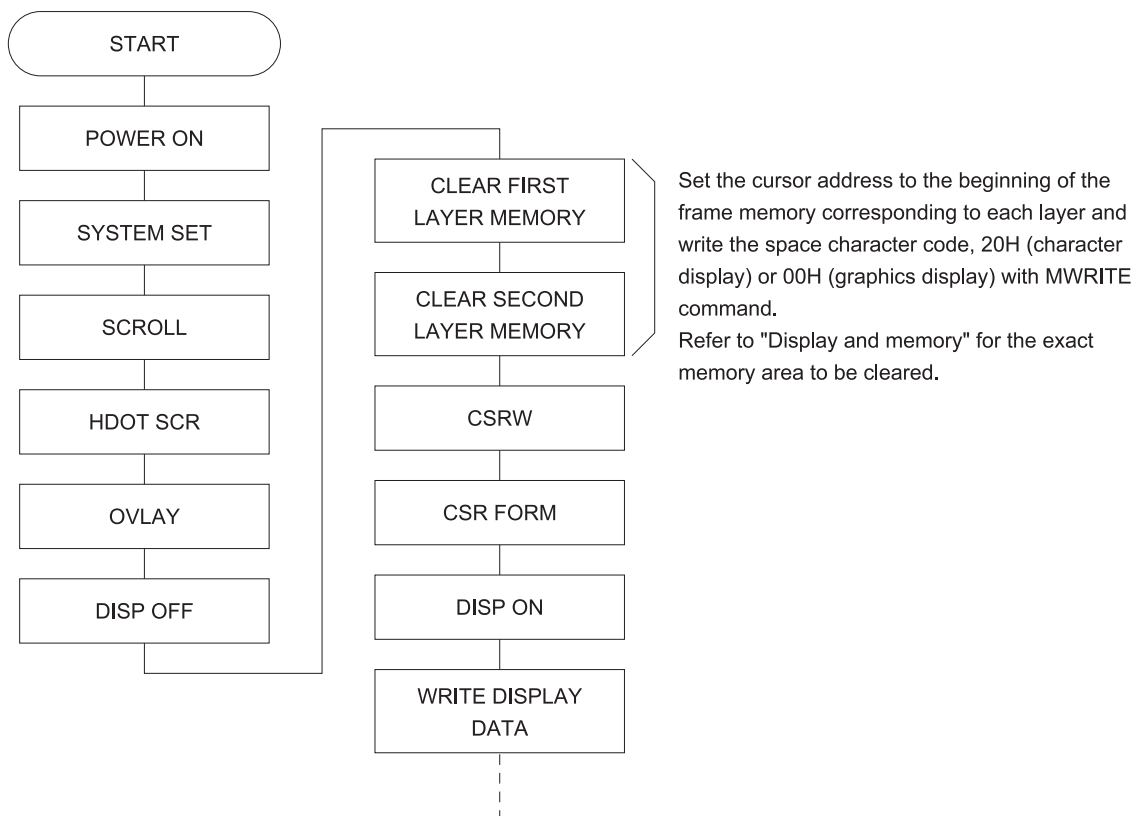

Figure 9 Display Data RAM

3.7 Example of an Initial Setting



In the combination of characters and graphics

- Requirements
 - 128×128 dots : 1 screen driving method (1/128 duty)
 - First layer : Character screen
 - Second layer : Graphics screen
 - Character font : 8×8 dots
 - CG RAM unused
 - fOSC = 6 MHz, Frame frequency = 71.2 Hz

- Assigning display memory
 - First layer (Character screen)
 - Characters in the horizontal direction = $128/8 = 16$
 - Characters in the vertical direction = $128/8 = 16$
 - Consequently, the required memory size is $16 \times 16 = 256$ bytes
 - Second layer (Graphics screen)
 - Characters in the horizontal direction = $128/8 = 16$
 - Characters in the vertical direction = $128/1 = 128$
 - Consequently, the required memory size is $16 \times 128 = 2048$ bytes

[Display and memory]

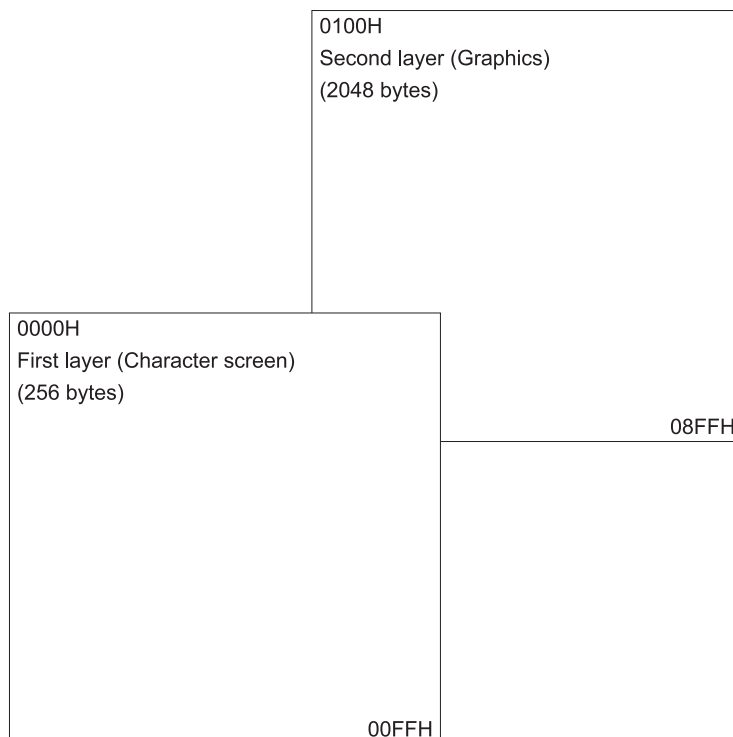
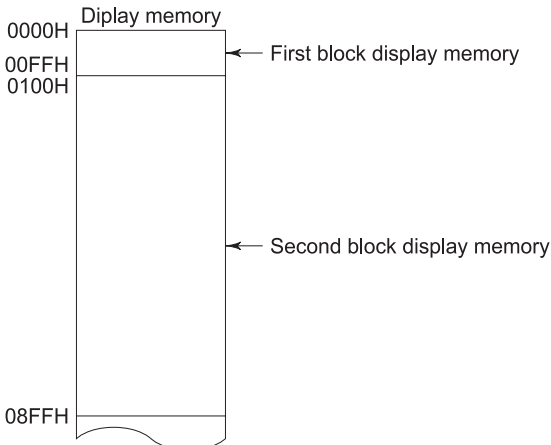
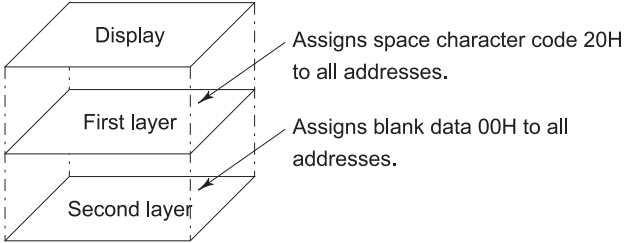
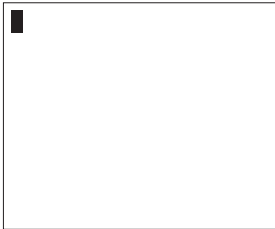
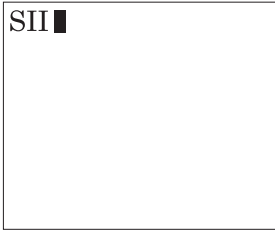

Figure 11 Display and memory

No.	Command	Operation
1	POWER ON	
2	WAIT FOR POWER SUPPLY TO BE STABILIZED	Sets VDD \geq 4.5V and waits more than 3 msec after completing external resetting.
3	SYSTEM SET C = 40H P1 = 30H P2 = 87H P3 = 07H P4 = 0FH P5 = 49H P6 = 7FH P7 = 10H P8 = 00H	Initializes LCD controller M0 : Internal CG ROM M1 : No compensation in bit D6 (CG RAM 32 characters MAX.) M2 : Character font size in the Y direction (8 dots) W/S : 1 screen driving method IV : No compensation in the top line FX : Character field in the X direction (8 dots) WF : 2-frame AC drive FY : Character field in the Y direction (8 dots) C/R : Characters in the X direction (Number of addresses) (16 characters/line) TC/R : Total characters in the X direction (Number of addresses) (73 characters/line) fosc = 6 MHz, Frame frequency = 71.2Hz L/F : Display lines in the Y direction (128) AP : Addresses in the X direction of virtual screen (16 addresses)
4	SCROLL C = 44H P1 = 00H P2 = 00H P3 = 7FH P4 = 00H P5 = 01H P6 = 7FH	Sets the start address of the first block screen to 0000H. Sets the display lines of the first block screen to 128. Sets the start address of the second block screen to 0100H. Sets the display lines of the second block screen to 128. 

No.	Command	Operation
5	HDOT SCR C = 5AH P1 = 00H	Sets the dot shift in the X direction to 0.
6	OVLAY C = 5BH P1 = 00H	MX1, MX0 : Simple overlay (OR) DM1 : First block screen (Character mode) DM2 : Third block screen (Character mode) OV : Combination of character mode and graphics mode
7	DISP ON/OFF C = 58H P1 = 16H	D : All screen display OFF FC1, FC0 : Blinking with cursor ON (Approx. 2 Hz) FP1, FP0 : First block screen display ON FP3, FP2 : Second block screen display ON FP5, FP4 : Third block screen display OFF
8	CLEAR FIRST LAYER DISPLAY DATA CSRW C = 46H P1 = 00H P2 = 00H CSR DIR C = 4CH MWRITE C = 42H P1 = 20H P2 = 20H . . . Pn = 20H, (n = 256)	Writes space character code 20H onto the corresponding first layer memory (character screen). Sets the VRAM address corresponding to the start address of the first block screen (home address). Sets "+1" to the automatic shift direction of the address counter. Sets the space code. Sets the space code. . . . Sets the space code.



No.	Command	Operation
9	<p>CLEAR SECOND LAYER DISPLAY DATA</p> <p>CSRW C = 46H P1 = 00H P2 = 01H</p> <p>MWRITE C = 42H P1 = 00H P2 = 00H . . . Pm = 00H, (m = 2048)</p>	<p>Writes blank data 00H (dot light OFF) onto the corresponding memory of the second layer (graphics screen).</p> <p>Sets the VRAM address corresponding to the start address of the second block screen (home address).</p> <p>Sets the blank data. Sets the blank data. . . . Sets the blank data.</p>
10	<p>CSRW C = 46H P1 = 00H P2 = 00H</p>	<p>Sets the cursor address to the start address of the first block screen (home position).</p>
11	<p>CSR FORM C = 5DH P1 = 04H P2 = 86H</p>	<p>CRX : Cursor size in the X direction (5 dots) CRY : Cursor size in the Y direction (7 dots) CM : Block cursor</p>
12	<p>DISP ON/OFF C = 59H</p>	<p> Cancels "All screen display OFF".</p> <div data-bbox="1091 1245 1441 1473" style="text-align: right; margin-top: 20px;">  <p>Screen</p> </div>
13	<p>CSR DIR C = 4CH</p>	<p>Sets the cursor shift direction to right.</p>
14	<p>MWRITE C = 42H P1 = 20H P2 = 53H P3 = 49H P4 = 49H . . .</p>	<p>Sets the space code. Sets the character code of "S." Sets the character code of "I." Sets the character code of "I." . . .</p> <div data-bbox="1091 1767 1441 1995" style="text-align: right; margin-top: 20px;">  <p>Screen</p> </div>

3.8 Example of the MPU Interface

3.8.1 80 series

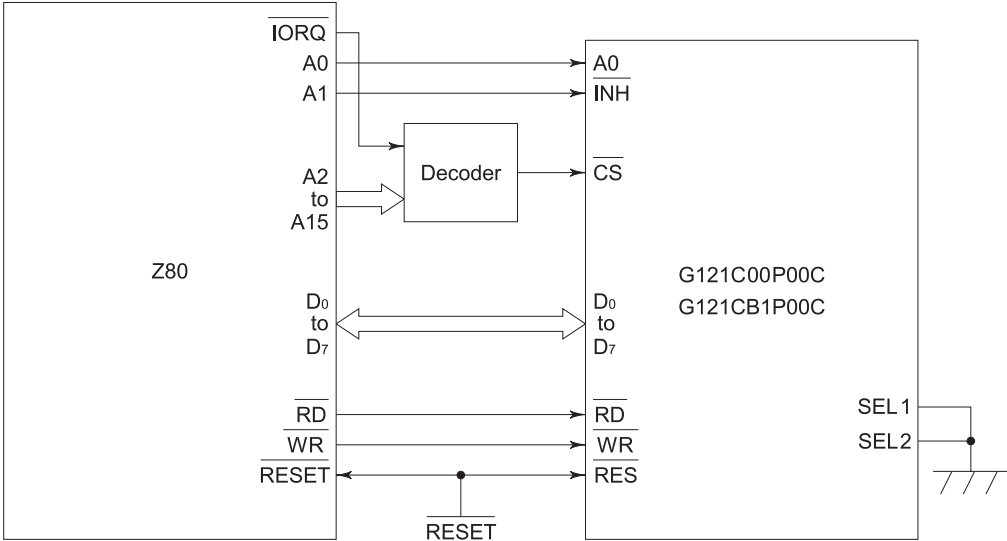

Figure 12

3.8.2 68 series

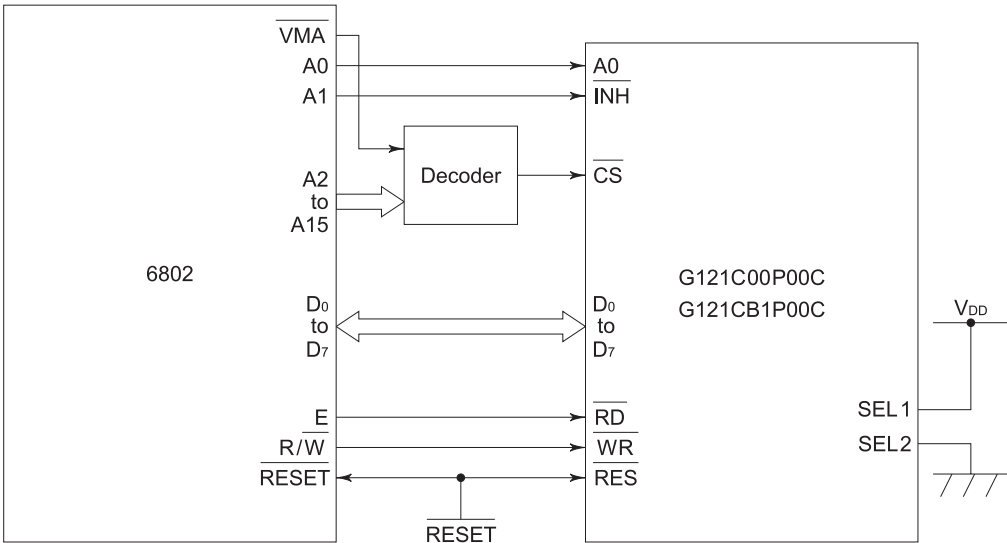

Figure 13

4. LED BACKLIGHT

4.1 Absolute Maximum Ratings

Item	Symbol	Standard	Unit
DC forward current	I_F	200*	mA
DC reverse voltage	V_R	8	V
Allowable dissipation	P_D	950	mW
Operating temperature range	T_{opr}	-20 to +70	°C
Storage temperature range	T_{stg}	-30 to +80	°C

* Forward current reduction characteristics : The absolute maximum ratings of forward current depends on the ambient temperature.

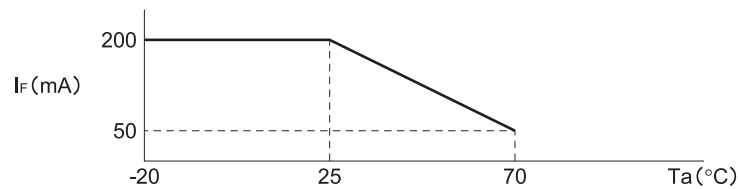

4.2 Electro-optical Characteristics

$T_a=25^\circ\text{C}$

Item	Symbol	Conditions	Min.	Typ.	Max.	Unit
Forward voltage	V_F	$I_F=100\text{mA}$	3.7	4.1	4.5	V
Reverse current	I_R	$V_R=8\text{V}$	—	—	300	μA

4.3 LED Backlight Diagram

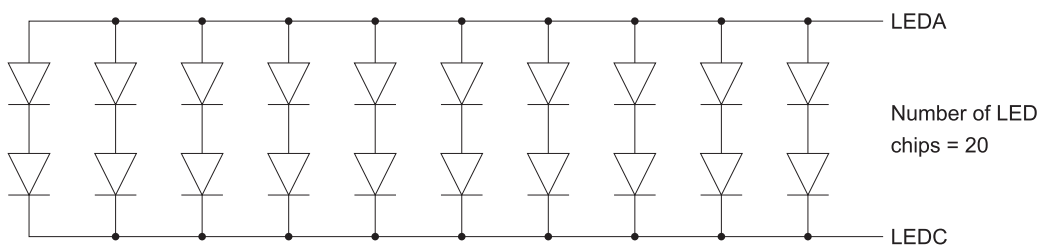

4.4 Brightness (Top surface of LCD)

Item	Symbol	Min.	Typ.	Max.	Unit
Surface brightness (Center part of LCD panel)	B_P	1.0	1.7	—	nit

Measurement conditions and measuring instruments

- $T_a = 25^\circ\text{C} \pm 3^\circ\text{C}$
- $I_F = 100\text{mA}$
- $V_{LC} = \text{Optimum LCD driving voltage}$
- The measurements must be made after LED lights for 30 minutes.
- Measuring instrument : BM-7 (TOPCON)
- 30 to 85%RH
- $f_{FLM} = 71.4\text{Hz}$
- Display OFF (All display data = "L")

4.5 Lifetime

Item	Measurement conditions	Standard	Unit
Lifetime*	Ta=25°C±10°C IF=100mA	50,000 or more	hrs

*Definition of lifetime : Time required for the brightness to be reduced to 1/2 of the initial brightness.

4.6 Examples of LED Backlight Drivers

(1) Circuit Example1

Figure 14 shows an example of a basic LED backlight driver.



Figure 14 LED Backlight Driver Example 1

The resistance R in the figure is a limiting resistor for the LED forward current and determines the current that flows into the LEDs. The forward current is temperature-dependent. Therefore the current must be reduced, especially at higher temperatures. Refer to “Forward Current reduction characteristics” in 4.1 for the temperature-dependency. Because the operating temperature range of the G121C is -20°C through +70°C, the limiting resistance must be determined so that the forward current is 50 mA or less at +70°C.

Table 6 shows forward voltage VF of LED backlight at each temperature.

Table 6 Forward voltage at each temperature

Temperature (Ta)	Requirements	VF min.	VF typ.	VF max.
-20°C	IF=100mA	3.9V	4.3V	4.7V
+25°C	IF=100mA	3.7V	4.1V	4.5V
+70°C	IF=50mA	3.4V	3.6V	3.9V

The resistance value R is calculated using the following equation. See Figure 14.

$$R = \frac{V_{IN} - V_F}{I_F} (\Omega)$$

V_{IN} = Input voltage (power supply voltage) (V)
 V_F = LED forward voltage (V)
 I_F = Allowable LED forward current (A)

The forward current on the above value of the resistance is 50 mA or less at 25°C. The surface brightness of the LED backlight varies according to the forward current as shown in Figure 15. Consequently, the brightness becomes 30% compared to the case described in “4.4 brightness” (IF = 100 mA).

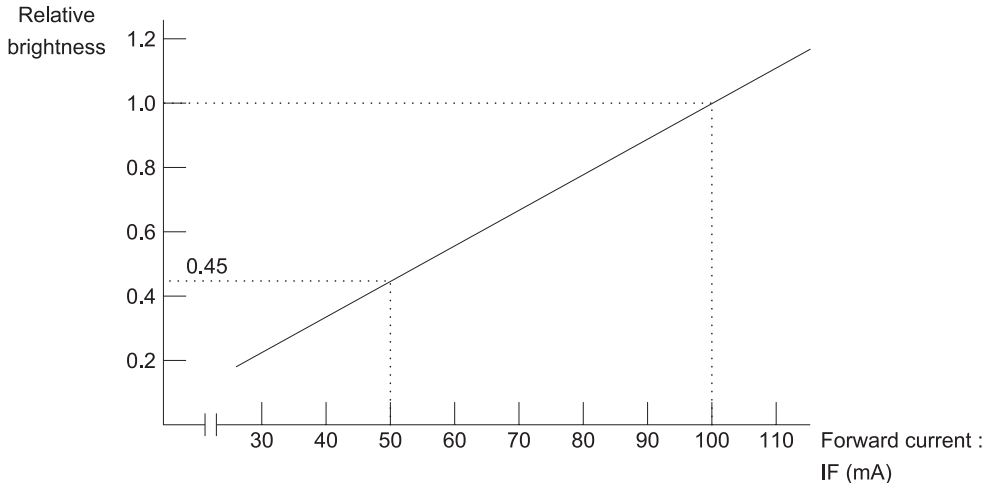

Figure 15 Forward Current-Brightness Characteristics (Ta = 25°C)

(2) Circuit Example 2

Using a thermo-sensitive device such as a thermistor and a transistor, set them to approximately $I_F = 100 \text{ mA}$ at 25°C and design the circuit so that I_F becomes less as the temperature rises to assure the brightness at 25°C (2 nit).

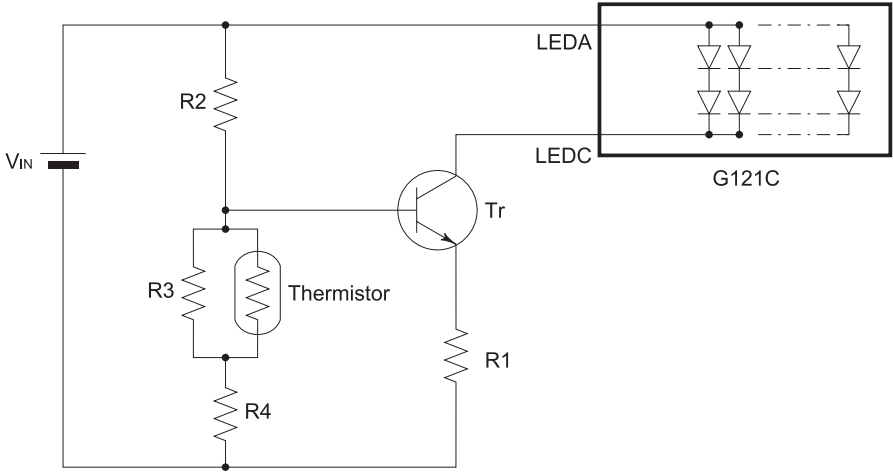

Figure 16 LED Backlight Driver Example 2

5. PRECAUTIONS

Safety

- If the LCD panel is damaged, be careful not to get the liquid crystal in your mouth and not to be injured by crushed glasses.
- If you should swallow the liquid crystal, first, wash your mouth thoroughly with water, then, drink a lot of water and induce vomiting ; and then, consult a physician.
- If the liquid crystal should get in your eye, flush your eye with running water for at least fifteen minutes.
- If the liquid crystal touches your skin or clothes, remove it and wash the affected part of your skin or clothes with soap and running water.
- Use the LCD module within the rated voltage to prevent overheating and/or damage. Also, take steps to ensure that the connector does not come off.

Handling

- Avoid static electricity, as it will damage the CMOS LSI.
- The LCD panel is made of plate glass. Do not hit, crush, or bend it.
- Do not remove the panel or frame from the module.
- The polarizer of the display is very fragile. Handle it with care.

Mounting and design

- Mount the module using the specified mounting parts and holes.
- To protect the module against external pressure, place a transparent plate (e.g., acrylic or glass) on the module, leaving a small gap between the display surface and transparent plate.

☆ Example

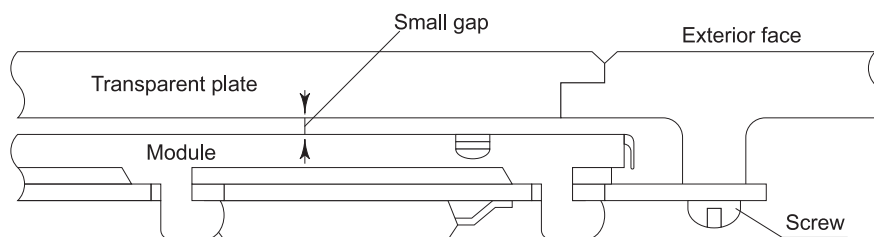

- Keep the module dry. Avoid condensation to prevent the transparent electrodes from being damaged.

Storage

- Store the module in a dark place, where the temperature is $25^{\circ}\text{C} \pm 10^{\circ}\text{C}$ and the relative humidity is below 65%.
- Do not store the module near organic solvents or corrosive gases.
- Keep the module (including accessories) safe from vibration, mechanical shock and external pressure.
- Black or white air-bubbles may be produced if the module is stored for a long time in the lower temperature or mechanical shocks are applied onto the module.

Cleaning

- Do not wipe the polarizer with a dry cloth, as it may scratch the surface.
- Wipe the module gently with a soft cloth soaked with a petroleum benzine.
- Do not use ketonic (ketone) solvents (ketone and acetone) or aromatic solvents (toluene and xylene), as they may damage the polarizer.

Index

— A —

Adjustment terminal for liquid crystal driving voltage	7
Allowable dissipation	24

— B —

Bias	1, 4, 11
Bias voltage generator	8, 11
Block diagram	8
Brightness	24, 25, 26

— C —

CG RAM	18, 19
CG ROM	1, 18
Cleaning	27
Commands	13, 14, 15, 17, 18, 20
Common drive waveform	9
Common driver	8, 9
Contrast	4, 5
Current consumption	3

— D —

Definition of angle	5
Definition of contrast	5
Definition of response time	5
Definition of viewing angles	5
Display data RAM	1, 8, 18
Display data shift clock	9
Display on/off	7
Dot dimensions	2
Dot pitch	2
Drive waveform	9

— F —

Forward current	24, 25, 26
Forward voltage	24, 25
Frame frequency	3, 5, 19, 20

— I —

I/O terminal functions	7
Initialize	7, 16, 18

	Input voltage	3, 25
	Interface	1, 12, 13, 24
— L —		
	LCD controller	1, 7, 8, 9, 10, 12, 13, 16, 17, 18
	LC operating voltage	7, 10, 13
	Lifetime	6, 25
	Limiting resistor	25
— M —		
	M ⁺ generator	8, 11
— O —		
	One-common line timing signal	9, 11
	One-frame timing signal	9, 11
	Operating temperature	2, 24
	Operational amplifier	10, 11
— P —		
	Power supply voltage	2, 25
— R —		
	Forward current reduction characteristics	24, 25
	Reset	7, 16
	Resistance division	11
	Response time	4, 5
	Reverse current	24
— S —		
	SED1335F	1, 8, 9, 17
	Segment drive waveform	10
	Segment driver	8, 9
	Storage	27
	Storage humidity	2
	Storage temperature	2, 24
— T —		
	Timing	14, 15, 16
— V —		
	Viewing angle	4
	Viewing area	2
	V _{opr} control circuit	8, 10

Seiko Instruments Inc.

Head Office

Components Sales Division
1-8, Nakase, Mihama-Ku. Chiba-shi, Chiba 261-8507. Japan
Phone : 043-211-1216 FAX : 043-211-8032

Seiko Instruments U.S.A. Inc.

Electronic Components Division
2990 W. Lomita Blvd., Torrance Calif. 90505, USA Phone : 310-517-7770 FAX : 310-517-8131

Seiko Instruments GmbH

Siemensstrasse 9b, 63263 Neu-Isenburg, Germany Phone : 49-6102-297-122 FAX : 49-6102-297-116

Seiko Instruments (H.K.) Ltd. Sales Division

4-5/F, Wyler Centre 2, 200 Tai Lin Pai Road, Kwai Chung, N. T., Kowloon, Hong Kong
Phone : 852-24218611 FAX : 852-24805479

Seiko Instruments Taiwan Inc.

4FL, No.40, Sec.2, Min Chuan E., Taipei, Taiwan, R.O.C.
Phone : 886-2-563-5001 FAX : 886-2-521-9519

Seiko Instruments Singapore Pte. Ltd

2, Marsiling Lane Singapore 739144
Phone : 65-2691370 FAX : 65-2699729